

## A New Test Method for UKR Tibial Tray Fatigue Testing

Gokce Yildirim, John Parker

MAKO Surgical Corp.

**Statement of Purpose:** Unicondylar Knee Replacement (UKR) was first introduced in the 1970s as a cemented implant, and since then has been offered with a cementless option. Implant manufacturers have utilized both versions and clinical outcomes show a relatively successful history. However, with the possible failure mechanisms associated with the complex designs such as periprosthetic tibial fractures, aseptic partial loosening, and insert fractures; a more rigorous test plan is required to ensure the effectiveness of the implants. This paper proposes a test method specifically for the fatigue testing of the tibial tray.

**Methods:** A clinical outcomes literature review was performed to identify various failure modes associated with UKRs. Fatigue failure of tibial trays was specifically identified in one study for Smith & Nephew Journey Deuce knee, leading to the proposal of this test method (Figure 1)<sup>1</sup>. Studies which led to the ASTM F1800 standard<sup>2</sup> were reviewed and the cantilever type test method was found not to be representative of the clinical failure observed. A 3 point bend test was devised where the implant would be supported solely on the anterior and posterior edges with the mid-section left unsupported. Based on the x-ray images (Figure 1A), the high point on the posterior and a lower anterior support could potentially cause this type of a loading profile. The currently observed issues relating to the flatness of the cut can cause this type of a raised posterior bone. This may be due to fact that the blade tip reaching the posterior can skive with the stresses caused by the denser cortical bone encountered at the posterior wall of the tibia.

Based on these assumptions, an FEA model of the implant was created and loaded with a poly puck at the center of the implant. The loading metal ball/poly puck model was introduced by the F1800 and was found to be applicable to this test method.

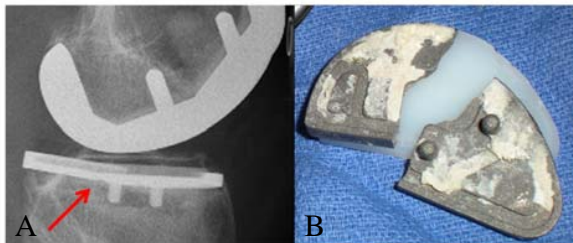

Figure 1. Retrieved failed S&N Journey Deuce, courtesy Palumbo et al.

**Results:** Our FEA analysis predicts the peak stresses on the tibial tray, which would lead to the observed clinical failure (Figure 2). The application of the poly puck at the center of the tibial tray is shown to be an acceptable substitution to the use of a full tibial insert. Based on these results, a fixture which supports the anterior and posterior edges of the tibial tray was designed to allow the mid-section of an implant to remain unsupported. Poly pucks can be made and loaded with a standard fatigue

machine which is usually used to run the F1800 tests. The test fixture should allow deflection while constricting A/P and M/L displacements, which can occur at higher fatigue test cycles at the range of 20Hz, as proposed by F1800.

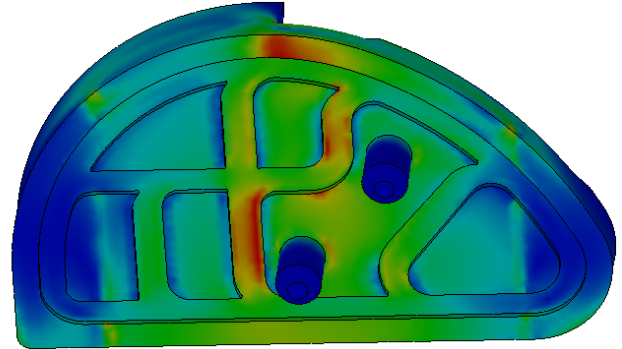

Figure 2. FEA Analysis on S&N Journey Deuce design

### Conclusions:

We have demonstrated a technique to replicate the worst case failure mode of a known implant failure. We believe that the proposed test setup can be used to benchmark various implant designs against known clinically successful UKRs. Ideally, the next step of our proposal would be to test the S&N implant in our model setup to establish an acceptable load, illustrating that the implants could survive the well-established 10 million cycles of fatigue loading. F1800 calls for a load of 900N based on the clinical failure of an implant replicated in a test setting. For an implant that is designed to support approximately 70% of the knee joint load, 630N would be a reasonable starting point.

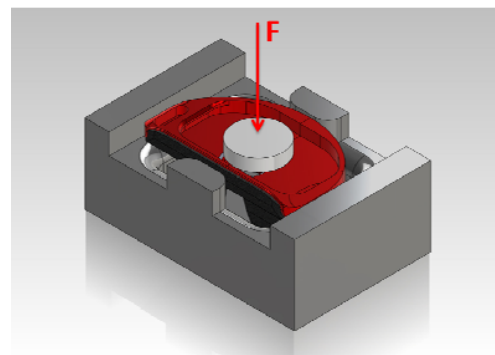

Figure 3. Test setup

### References:

1. Palumbo BT. J Arthroplasty. 2011; Vol 26. No 6 Suppl. 1:40-45.
2. ASTM F1800-12 Standard Practice for Cyclic Fatigue Testing of Metal Tibial Tray Components of Total Knee Joint Replacements.